



DBK15™

Universal Current/Voltage Input Card



Compatibility: ✓ LogBook ✓ DaqBook ✓ DaqLab ✓ DaqScan ✓ DaqBoard/2000 Series

Features

- Ideally suited for 4 to 20 mA measurements
- Can measure up to $\pm 30V^*$
- Provides 16 differential input channels
- Offers user-configurable current or voltage input

Each DBK15™ multiplexing input card provides 16 channels of current or voltage input to IOtech's data acquisition systems. A system can accept up to 16 DBK15 cards, for a total of 256 potential analog input channels per system.

The DBK15 features a 16-channel multiplexer and a programmable gain input amplifier. Its durable component sockets accept resistors that configure each channel for either current-to-voltage conversion or for voltage attenuation. The DBK15 is supplied with sixteen precision 250 Ohm resistors for making 4 to 20 mA measurements, and sixteen sets of 6:1 voltage dividers for accommodating up to $\pm 30V^*$ inputs.

The DBK15 can also accept other, user-supplied resistor values, facilitating user-selectable current-to-voltage conversion or voltage attenuation factors.

When employed without resistors, the DBK15 provides 16 differential voltage inputs, which accommodate $\pm 5V$ full scale inputs.

The DBK15's input amplifier is software programmable for x1 or x2 gain per channel, and for unipolar 0 to +10V or bipolar -5 to +5V input per channel.

Voltage & Current Measurements

The voltage and current input ranges shown in the accompanying charts supply a full-span signal to the A/D converter, providing maximum measurement resolution.



The DBK15 provides 16 channels of current or voltage input

Voltage Measurements. The DBK15 accommodates voltage measurements beyond the standard 10V range, accepting voltage divider resistors for up to $\pm 30^*$ VFS inputs. You can obtain any combination of input ranges by simply installing the appropriate resistor combination on the DBK15 card. The card's on-board programmable gain instrumentation amplifier (PGIA) can be set for a $\pm 5V$ output span or a 0 to +10V output span, allowing users to set the A/D converter for either configuration. The DBK15 can also be

configured to accept $\pm 5V$ full scale inputs without attenuation resistors.

Current Measurements. The DBK15 is ideal for accommodating transducers with 4 to 20 mA output; it is only necessary to install the supplied 250 Ohm resistors in the appropriate location on the board. The DBK15's on-board PGIA is software selectable for either a $\pm 5V$ output span or a 0 to +10V output span. To accommodate other current ranges, you need only install a different shunt resistor for the DBK15.

Voltage Ranges			
Input Voltage		Configuration	
Min	Max	Attenuation	Gain
0	+5V	—	x2
0	+10V	—	x1
-2.5	+2.5V	—	x2
-5	+5V	—	x1
-15	+15V	6:1	x2
-30	+30V*	6:1	x1
other	other	other	x1, x2

Current Ranges			
Input Current		Configuration	
Min	Max	Shunt	Gain
0	+20 mA	250 Ohm	x2
-20 mA	+20 mA	250 Ohm	x1
other	other	other	x1, x2

* $\pm 10V$ to $30V$ input signals can be measured by installing $<10K$ Ohms attenuation resistors on the card. For 1% or greater accuracy, the output impedance of the measured signal should be <100 Ohms. To accurately measure high-voltage signals with >100 Ohms of output impedance, the DBK8 high-voltage input card should be used rather than the DBK15. The DBK8 has very high-input impedance, which is ideal for measuring high-voltage input signals.



DBK15™

Specifications & Ordering Information

Specifications

Connector: DB37 male, mates with P1*; screw terminals provided for signal connection

Gain Ranges: x1, 2

Number of Channels: 16 differential

Voltage Input Ranges: 0 to +10 VDC, ±5 VDC (less attenuating resistors)

Current Input Range: ±20 mA max

Gain Accuracy: ±0.05% typ; ±0.25% max

Maximum Input Voltage (without damage): ±35 VDC

Slew Rate: 10 V/μs

Settling Time: 2 μs to 0.01%

CMRR: 80 dB min

Non-Linearity: 0.002% typ; 0.015% max

Unattenuated Bias Current: 150 pA typ; 0.2 μA max @ 25°C

Offset Voltage: ±(0.5 + 5/G) mV @ 25°C typ; ±(2.0 + 24/G) mV @ 25°C max

Offset Drift: ±(3 + 50/G) μV/C° typ; ±(12 + 240/G) μV/C° max

Power Consumption: 485 mW

DBK15 Universal/Current Voltage Input Card Block Diagram

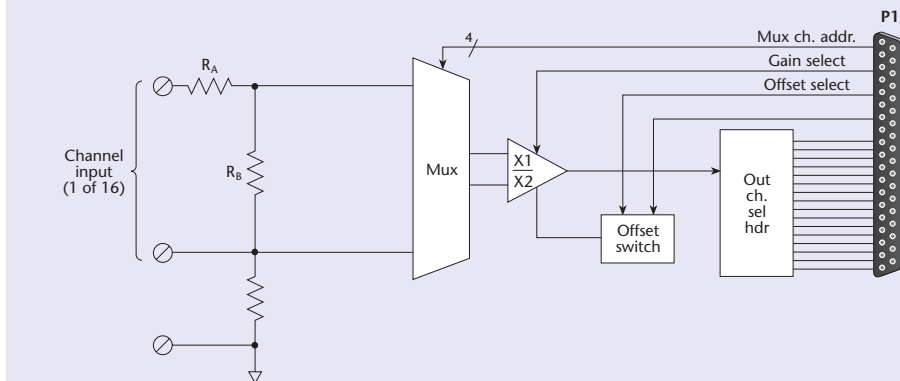

Ordering Information

Description	Part No.
Universal current/voltage multiplexing input card with 16 user-installable 6:1 voltage attenuation resistors and 16 user-installable 250 Ohm current shunt resistors	DBK15

Cables

For use with DBK10, use CA-37-x ribbon cable, or contact factory of additional cabling options

For use with DBK60 or LogBook360, no cable is required (except from DBK60 or LogBook/360 to the A/D mainframe)

For use with no enclosure, use CA-37-x where x is the number of DBK devices attached

For use with DaqLab series (internal slots), use CA-255-2T with one board, or CA-37-2 for use with two DBK cards (or contact factory for additional cabling options)

For complete information on accessories and cables, visit www.iotech.com/acc

Related Products

LogBook	p. 75
DaqBook	p. 89
DaqLab	p. 103
DaqScan	p. 108
DBK10	p. 126
DBK41	p. 146
DBK60	p. 160
DaqBoard/2000 Series	p. 192

* Attachment to the DaqBoard/2000 series requires a DBK200, DBK201, DBK202, DBK203, DBK205, or DBK209 adapter